



DeMaMech Exchange Program 2005-2006



Personal Data

Name	Philip Donath
Home University	TU Berlin
Home Supervisor	Prof. Lucienne Blessing
Host University	Keio University
Host Supervisor	Prof. Toshiyuki Murakami
Research Topic	Intelligent Control in Human Assist Systems
Location	Hiyoshi, Yokohama

Redundant Manipulator

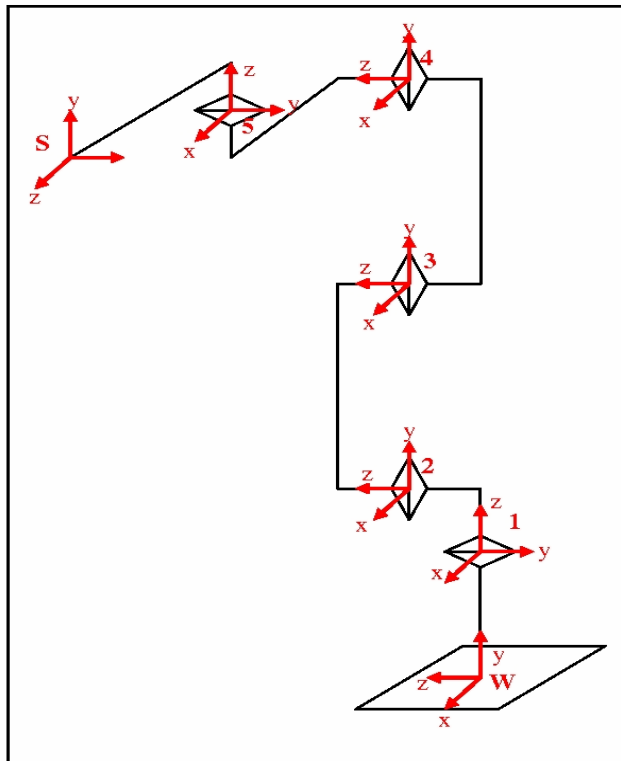

Kinematics

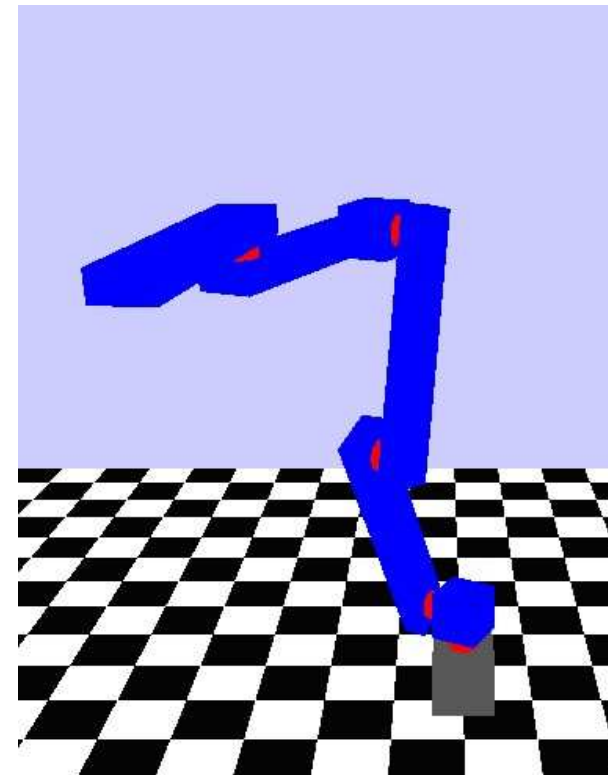

Simulation in OpenGL

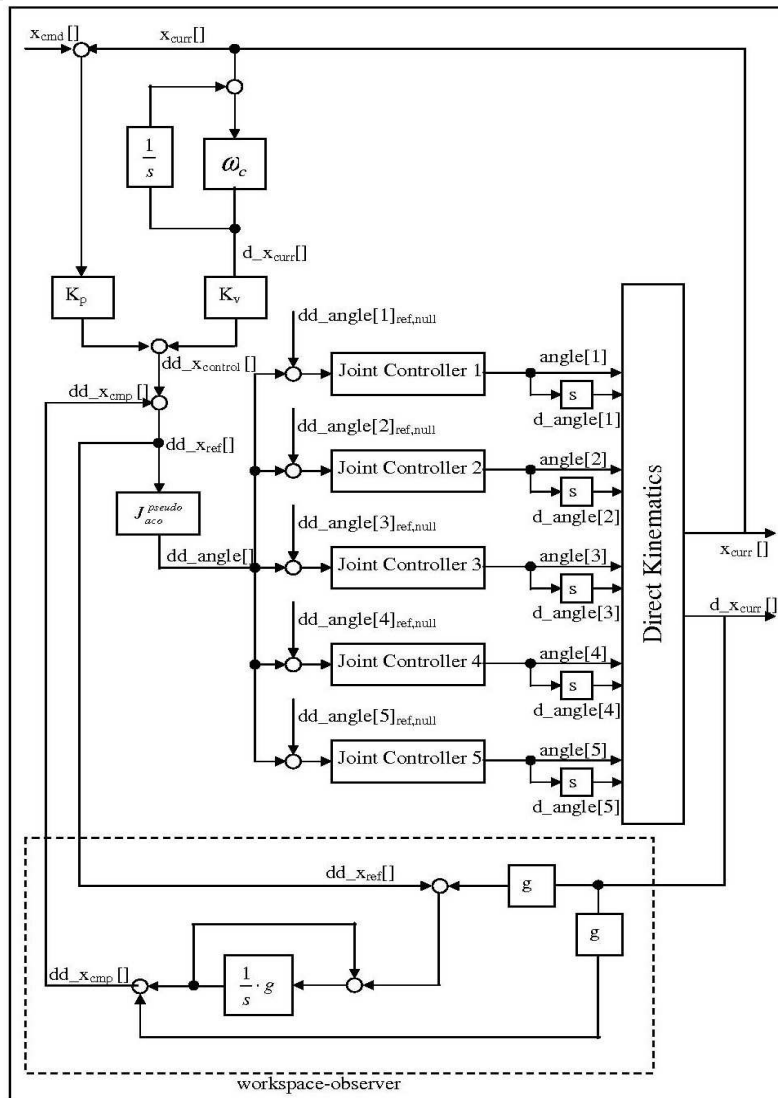

Control Algorithm

- Workspace and Nullspace Tasks
- PD-Controller
- Disturbance-Observers at joints
- Workspace-Observer

$$\ddot{q}^{ref} = \ddot{q}_x^{ref} + \ddot{q}_{null}^{ref}$$

Exchange Student Life

4



DeMaMech Exchange Program
2005-2006

