

**EU/JAPAN  
EXCHANGE PROGRAM**

2004-2005

Name: Jan Piot  
Home Institute: KULeuven  
Host Institute: Keio University

# Summary



---

- Lectures:

- Aerospace Propulsion
- Advanced Design and Production System
- Information Optics and Optical Measurements
- Advanced Course on Digital Communication Theory
- System Simulation
- Computer Architecture
- Computational Structural Mechanics

- Labwork

- Exchange student life

# Lectures

- 
- English spoken
  - Lectures: basic understanding of concepts
  - Self-study: library, laboratory,...
  - Evaluations by reports, contests or examinations
  - Classes end beginning of July
  - Examinations and final reports due to end of July

# Labwork: Comparison between an IPD and PID Controller for the Trajectory Control of an Electric Bicycle

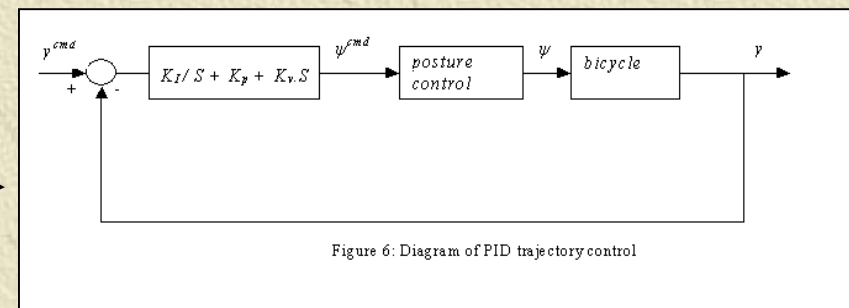
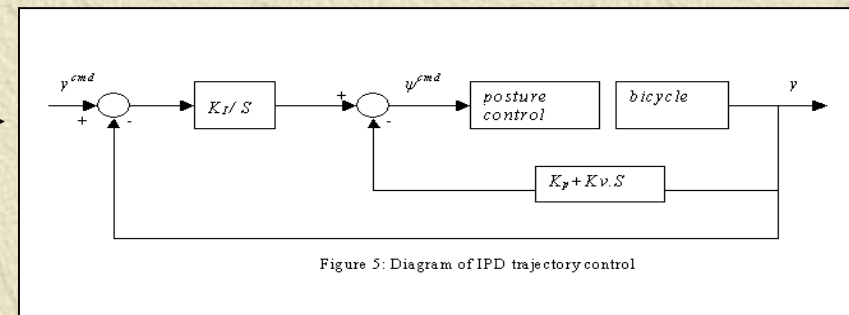
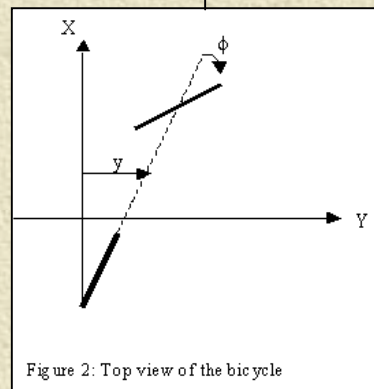
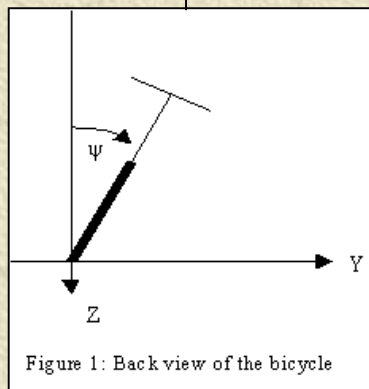

# Exchange Student Life

---

- Try to understand and speak Japanese
  - Most popular activity in Japan for going out is karaoke
  - Visited Kyoto, Osaka, Nara, Oita
  - Climbing Mt. Fuji is a must in Spring semester!
- 
- Close relation between professor and students
  - Labcamp: students get to know each other