

# Summary

---

## Osaka University

Hidenori Fujii

- Intercultural communication
- Lectures different from Japanese
- To get to know foreign students
- English conversation skill

# Research

## Ankle actuation for dynamic biped

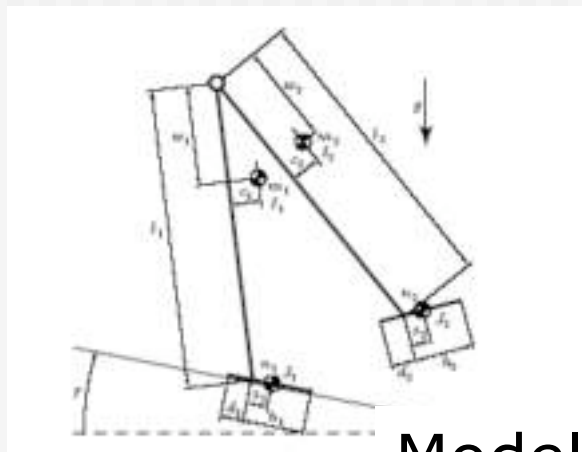

Model

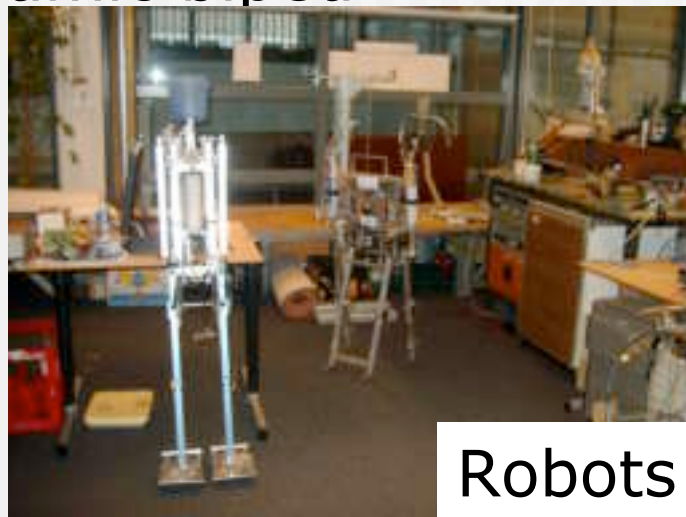

Robots

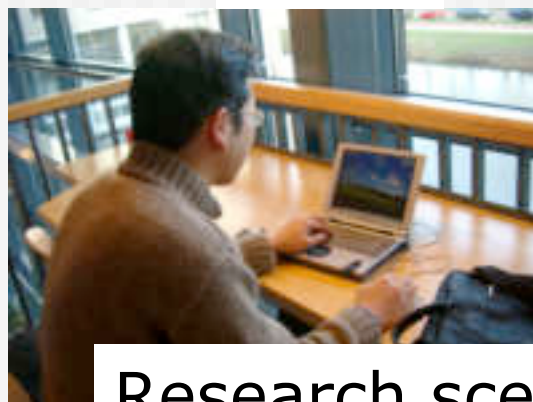

Research scene

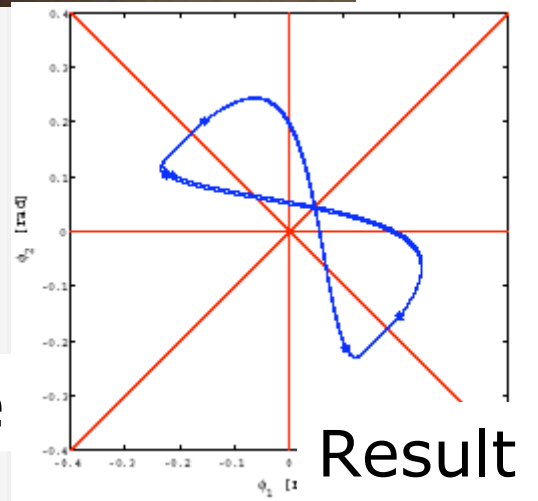

Result

# Lectures

- Control Theory(assignment)

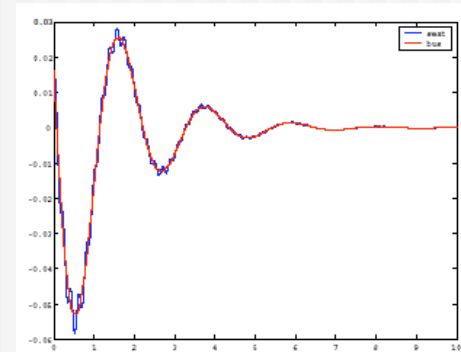
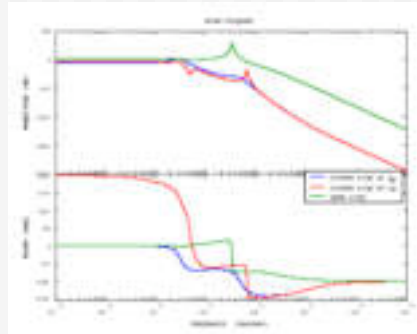
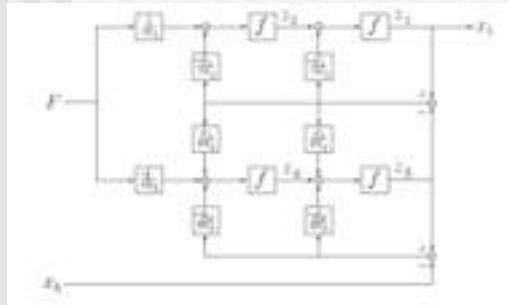

- Biomedical Engineering Design(design of prosthesis)

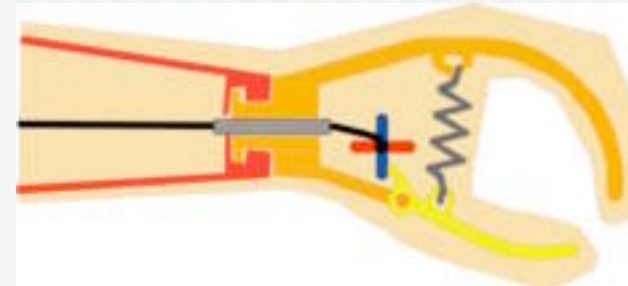

- Optimization in system and control

# Exchange student life

